

# Application Note: 3044

## Thermostat Interface Sequence of Operations

# Introduction

The Mitsubishi Electric US, Inc. Thermostat Interface (P/N PAC-US444CN-1) allows for a 3<sup>rd</sup> party 24VAC thermostat to control a Mitsubishi Electric HVAC system while still allowing the ability to use the benefits of inverter driven technology.

We have tested the Thermostat interface with Nest<sup>®</sup>, Lyric<sup>®</sup>, ecoBee<sup>®</sup>, and INNCOM<sup>®</sup> thermostats.

The algorithm used within the thermostat interface has been patented by Mitsubishi Electric US, Inc.. under US patent US20160252266A1.

## Thermostat Interface Dip Switch 2-6 Settings

The Thermostat Interface has 2 Dip Switch Banks that allow for additional settings to be configured during initial operation. It is important that Dip Switch 2-6 be set to ON. This will allow the system to benefit from the Mitsubishi Electric inverter driven technology and gives the indoor unit the ability to vary its capacity as needed.

## Target Method Sequence of Operation - Cooling

When the thermostat interface has dip switch SW 2-6 set to ON and the thermostat interface has Y1 energized, the indoor unit will turn on and be set to COOL mode. During this time, the indoor unit will adjust the set point to -2 degrees Fahrenheit from the space temperature. A set point difference of -2 degrees Fahrenheit from the space temperature will be maintained for five minutes.

After five minutes of a continuous call for cooling by input Y1 being energized with 24VAC, the thermostat interface will check the rate of change of the space temperature. If the thermostat interface measures that the rate of change is different than 1°F per 5 minutes, it will adjust the indoor unit capacity accordingly as well as comparing the first recorded space temperature with the current temperature:

- If the temperature difference is zero, no change will be made to the set point.
- If the temperature difference has increased, then the set point difference will be increased by 1°F.
- If the temperature difference has decreased, then the set point difference will be decreased by 1°F.
- If the unit is not able to meet demand, and a wire is connected to Y2, Y2 will also become energized and a second stage of cooling will become initiated. During this time, the indoor unit will operate at full capacity until the set point temperature is met.
- If Y1 is not energized and no other inputs to the thermostat interface are being powered, the unit will turn off.
- If the indoor unit is not meeting the 1°F per 5 minute cooling requirement, the indoor unit will reach full capacity in approximately 25 to 35 minutes.

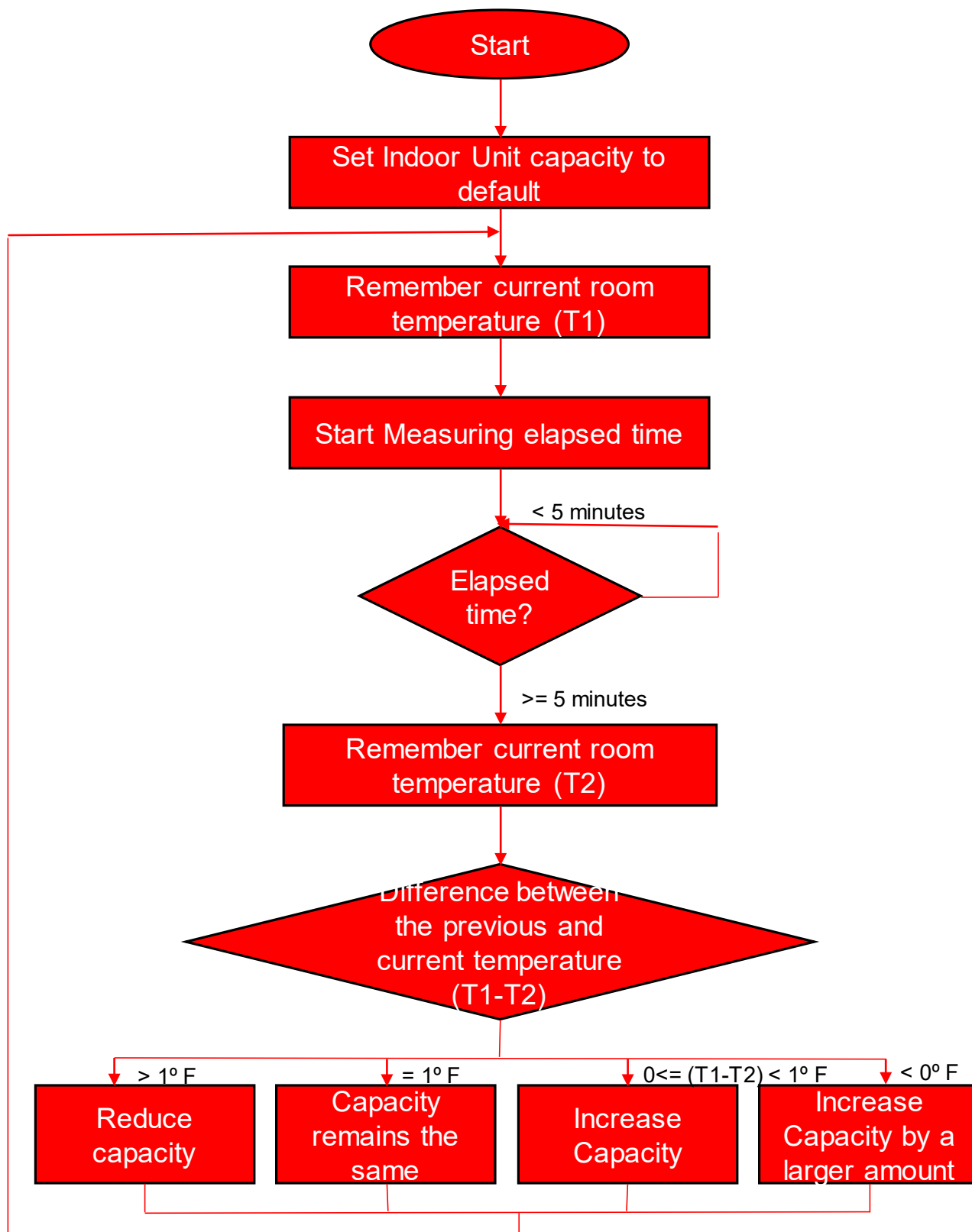

**Figure 2: Flowchart for Cooling**

## Target Method Sequence of Operation - Heating

When the thermostat interface has dip switch SW 2-6 set to ON and the thermostat interface has W1 energized, the indoor unit will turn on and be set to HEAT mode. During this time, the indoor unit will adjust the set point to 2 degrees Fahrenheit from the space temperature. A set point difference of 2 degrees Fahrenheit from the space temperature will be maintained for five minutes.

After five minutes of a continuous call for heating by input W1 being energized with 24VAC, the thermostat interface will check the rate of change of the space temperature. If the thermostat interface measures that the rate of change is different than 1°F per 5 minutes, it will adjust the indoor unit capacity accordingly as well as comparing the first recorded space temperature with the current temperature:

- If the temperature difference is zero, no change will be made to the set point.
- If the temperature difference has increased, then the set point difference will be increased by 1°F.
- If the temperature difference has decreased, then the set point difference will be decreased by 1°F.
- If the unit is not able to meet demand, and a wire is connected to W2, W2 will also become energized and a second stage of heating will become initiated. During this time, the indoor unit will operate at full capacity until the set point temperature is met.
- If W1 is not energized and no other inputs to the thermostat interface are being powered, the unit will turn off.
- If the indoor unit is not meeting the 1°F per 5 minute heating requirement, the indoor unit will reach full capacity in approximately 25 to 35 minutes.

\*The system waits for 30 seconds to allow for the coils to warm up to prevent cold air from reaching the homeowner

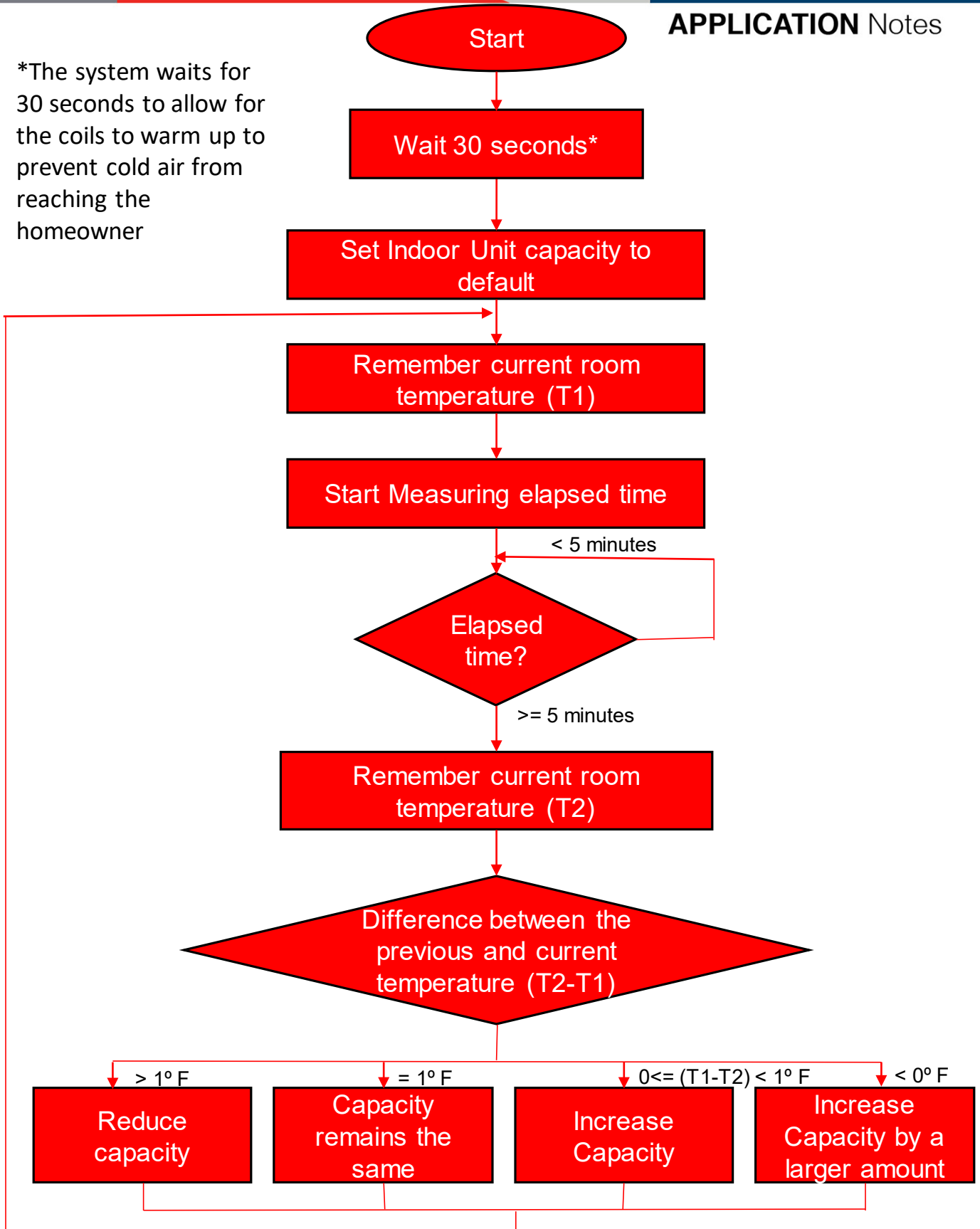

**Figure 3: Flowchart for Heating**

## Appendix: Additional Thermostat Interface Information

Table 1: Thermostat Interface Terminal Information

| <u>Label</u> | <u>Connector</u> | <u>Purpose</u>   |
|--------------|------------------|------------------|
| TC           | Common (In)      | To Transformer   |
| C            | Common (Out)     | To Thermostat    |
| TR           | 24VAC (In)       | To Transformer   |
| R            | 24VAC (Out)      | To Thermostat    |
| G3           | Fan High         | High Fan Speed   |
| G2           | Fan Medium       | Medium Fan Speed |
| G1           | Fan Low          | Low Fan Speed    |
| Y2           | Y2               | Stage 2 Cooling  |
| Y1           | Y1               | Stage 1 Cooling  |
| W2           | W2               | Stage 2 Heating  |
| W1           | W1               | Stage 1 Heating  |
| G            | G                | Fan              |

To operate the indoor unit via Thermostat Interface (PAC-US444CN-1) using a 24VAC thermostat in the heat pump configuration (using O/B with Y1 & Y2 output) requires a double pole- double throw relay as shown in Figure 4. This allows the 24VAC thermostat to use its auxiliary and dual fuel strategies with Mitsubishi Electric equipment. In some cases, an addition a single pole-double throw relay may be needed to power any auxiliary heat. Please refer the 24VAC thermostat documentation.

The Thermostat Interface is still needs to have wires terminated into TC, C, TR, R, Y2, Y1, W2, W1, and G.

See next page for an example of the Thermostat Interface wired to a Honeywell TH8320R thermostat with 2 stages of heat and a separate emergency heat source.

Figure 4: Wiring Diagram for 2 stage Heating/Cooling



## APPLICATION Notes

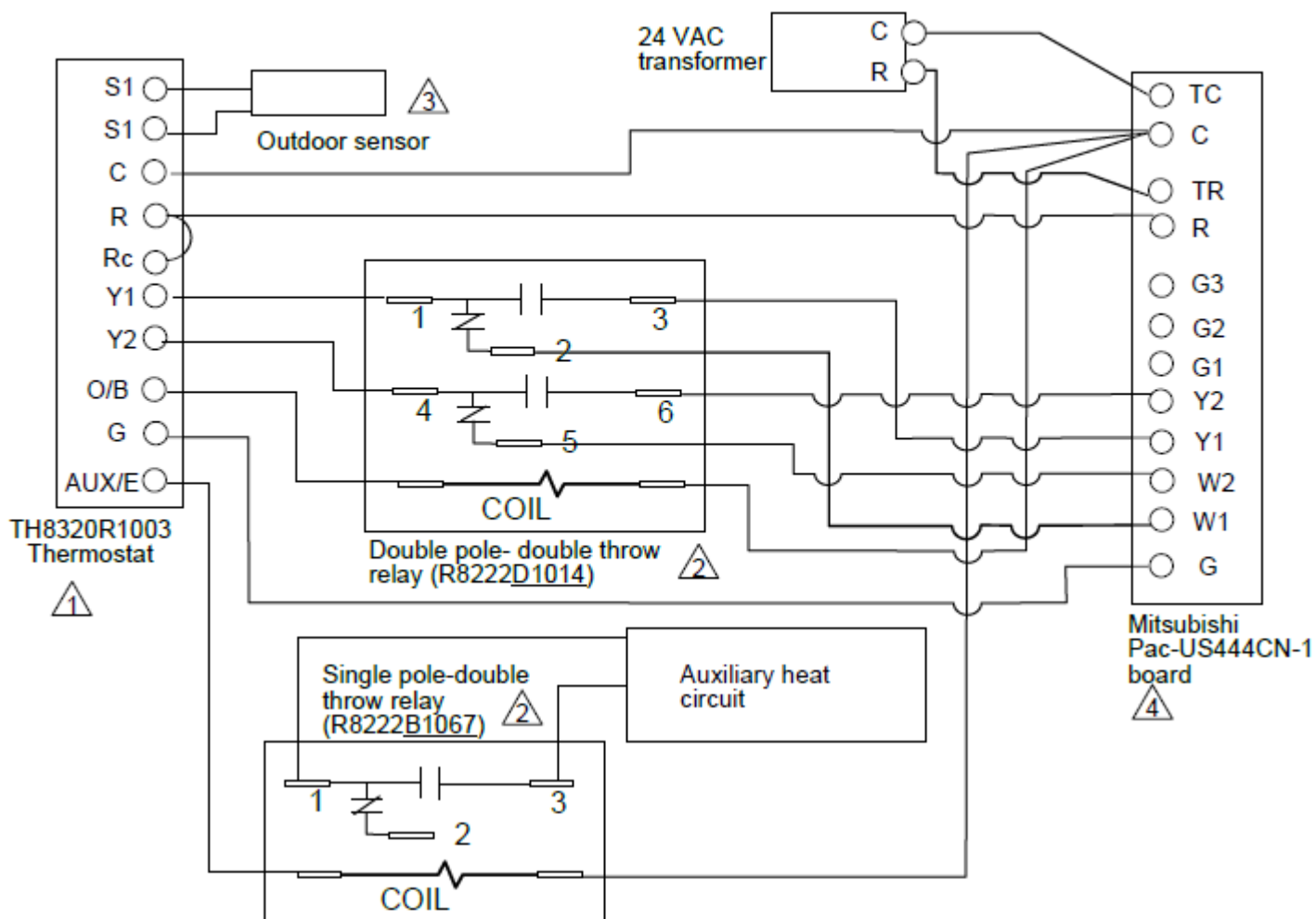

### NOTES

#### 1 Configuration settings for thermostat:

- Heat pump
- Dual fuel
- Cool changeover (reversing) valve
- Thermostat controls dual fuel
- Set balance point to desired setting
- Either wireless or wired outdoor sensor. Installer preference.

#### 2 Relays:

- If the auxiliary heater used is a line voltage heater, make sure to wire the heater and line voltage power in series with the 1 and 3 relay switch contacts. The installer must verify that it is up to code in their city to control a baseboard heater with a single-pole circuit (some codes require a 4 wire circuit with a positive off).
- The switch contacts on the R8222 relay can be used for 24 volt, 120 volt, or 240 volts. At 120 or 240 volts, they are rated for 20.8 amps.

#### 3 Outdoor sensor: (Wired or wireless. installer preference).

- Wireless outdoor sensor (C7089R1013)
- Wired outdoor sensor (C7089U1006) Wires to S terminals.

#### 4 Verify the Mitsubishi Pac-US444CN-1 board is compatible with your Mitsubishi mini-split heat pump. Connect the Pac-US444CN-1 board to the Mitsubishi unit and set the dipswitches on the Mitsubishi unit according to the Pac-US444CN-1 instructions.